

Installation Manual and Operating Instructions

TRUE BLUE POWER

**TB17
SERIES**

ADVANCED
LITHIUM-ION BATTERY

Manual Number
9018047



Revision K • July 23, 2021

FOREWORD

This manual provides information intended for use by persons who, in accordance with current regulatory requirements, are qualified to install this equipment. If further information is required, please contact:

True Blue Power
c/o Mid-Continent Instrument Co., Inc.
Attn: Customer Service Dept.
9400 E. 34th St. N.
Wichita, KS 67226 USA
Phone 316-630-0101
Fax 316-630-0723
www.truebluepowerusa.com
www.mcico.com

We welcome your comments concerning this manual. Although every effort has been made to keep it free of errors, some may occur. When reporting a specific problem, please describe it briefly and include the manual part number, the paragraph/figure/table number and the page number. Send your comments to:

True Blue Power
c/o Mid-Continent Instrument Co., Inc.
Attn: Technical Publications
9400 E. 34th St. N.
Wichita, KS 67226 USA
Phone 316-630-0101
Fax 316-630-0723

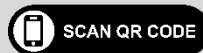

Download the current version of this installation manual using your smartphone or tablet.

© Copyright 2017
Mid-Continent Instrument Co., Inc.

TABLE OF CONTENTS

<u>SECTION 1</u>	<u>GENERAL DESCRIPTION</u>	<u>4</u>
1.1	INTRODUCTION	4
1.2	PHYSICAL ATTRIBUTES	4
1.3	UNIT ARCHITECTURE	4
1.4	TECHNICAL SPECIFICATIONS	5
1.5	IMPORTANT SAFETY INFORMATION	7
<u>SECTION 2</u>	<u>PRE-INSTALLATION CONSIDERATIONS</u>	<u>9</u>
2.1	COOLING	9
2.2	EQUIPMENT LOCATION	9
2.3	ROUTING OF CABLES	9
2.4	LIMITATIONS	10
2.5	MODIFICATION	10
<u>SECTION 3</u>	<u>INSTALLATION</u>	<u>11</u>
3.1	GENERAL	11
3.2	PRE-INSTALLATION INSPECTION	11
3.3	PARTS	11
3.4	INSTALLATION	12
<u>SECTION 4</u>	<u>OPERATION</u>	<u>16</u>
4.1	DESCRIPTION	16
4.2	OPERATIONAL MODES	16
4.3	ACTIVE MONITORING	18
<u>SECTION 5</u>	<u>CONFORMANCE</u>	<u>19</u>
5.1	DISPATCH VERIFICATION AND IN-FLIGHT MONITORING	19
5.2	ROUTINE MAINTENANCE	19
5.3	COMPONENT MAINTENANCE	21
5.4	STORAGE INFORMATION	21
5.5	END OF LIFE	22
5.6	DISPOSAL	22
5.7	ENVIRONMENTAL QUALIFICATION STATEMENT	23

REVISION HISTORY

Rev	Date	Detail	Approved
A	10/17/2013	Initial release.	BAW
B	12/10/2013	Miscellaneous revisions to grammar and content.	BAW
C	10/23/2015	Updates for MOD 1 monitoring signal definitions and other miscellaneous revisions.	BAW
D	03/21/2016	Updates for MOD 2 battery operational characteristics; added QTR 1727 and DO-160 Sections 10, 12 to Appendix 1 EQF.	BAW
E	04/22/2016	Added Modifications section (2.6).	WVC
F	06/23/2017	Added 6430017-2 and associated references; revised weight to 16.0 lbs.; clarified battery storage charge interval.	WVC
G	11/01/2017	Removed technical content not required for Installation and Operating Instructions.	WVC
H	05/04/2020	Updated style and brand to meet Marketing and Engineering guidelines. Section 1.5.1, updates to title and symbols. Inserted Section 5.7, Environmental Qualification Statement.	DLR
J	09/21/2020	Added 6430017-3 and -4 and associated references.	VAA
K	07/23/2021	Updated dimensions to single place precision.	MEK

SECTION 1 GENERAL DESCRIPTION

1.1 INTRODUCTION

The TB17 series Advanced Lithium-ion Battery, part numbers 6430017-(), is designed to deliver high current capability to start piston and light turbine aircraft engines and successively, provide DC power capacity to the primary electrical bus in the event of generator function loss. The TB17 is a sophisticated power system that utilizes state-of-the-art Nanophosphate® lithium-ion battery cell technology which provides improvements in performance, safety, life and weight when compared to traditional or competing aircraft batteries. Consideration given to key electrical and mechanical design principles yield compliance with regulatory standards and meet or exceed industry expectations. The TB17 is a complete battery solution that provides significant value and benefit to an aircraft designer, owner and operator.

The TB17 requires professional use and maintenance to deliver maximum performance and value as designed. This manual contains information related to the specifications, installation, operation, storage, scheduled maintenance and other related topics associated with the proper care and use of this product.

1.2 PHYSICAL ATTRIBUTES

The TB17 is a single, integrated component contained in a metal enclosure with positive and negative power terminals and a 7-pin circular communication connector. The top of the enclosure supports the use of a hold-down bar for typical aircraft mounting. There is a 1-inch diameter vent port on top of the unit for an exhaust connection that directs any released emissions appropriately.

1.3 UNIT ARCHITECTURE

The unit is comprised of three primary functional pieces:

- Battery modules
- “Switch” board; a printed circuit board assembly to control charging and discharging
- “Control” board; a printed circuit board assembly to serve as the battery management system

Each battery module consists of twenty-eight (28) cells, arranged in four strings of seven parallel cells connected in series. Two modules are connected in series to provide the total battery output. The modules are designed identically and each includes multiple temperature monitors and a heater. The cells are connected with welded bus bars which contain an individual fuse for each cell in the module.

The Switch board incorporates the ability to enable and disable charging or discharging depending on the health of the battery and associated conditions. It also contains a charge limiting function and current monitoring.

The Control board is the battery management system. The discrete logic circuitry monitors the battery functions and protects against such conditions as short circuit, over-temperature, over-discharge and others. The Control board also generates the battery status signals that are accessed through the 7-pin communication connector for cockpit monitoring and heater functionality control.

Additional components in the unit include Resistance Temperature Detectors (RTDs) that produce analog electrical signals accessible through the 7-pin connector for redundant temperature monitoring. There are two RTDs in the 6430017-1/-3 units and one in the 6430017-2/-4 units (hereafter referred to as -1, -2, -3, and -4, respectively).

1.4 TECHNICAL SPECIFICATIONS

Electrical Attributes	
Software / Complex Hardware	None
Power Input	28.8 volts DC Nominal, 34A Max
Power Output	26.4 volts DC Nominal, Continuous Current 500A; Power Peak Current (I _{PP}) 840A; Power Rated Current (I _{PR}) 600A
Battery Capacity	17 amp hours (Ah) @ 23°C

Table 1.1

Physical Attributes	
Weight	16.0 pounds (7.2 kg) -1 and -2 configurations 17.1 pounds (7.5 kg) -3 and -4 configurations
Dimensions (see Figure 1.1) (not including vent or connectors)	7.3 x 7.4 x 6.1 inches -1 and -2 configurations [185 x 188 x 155 mm] 7.3 x 9.4 x 6.1 inches -3 and -4 configurations [185 x 239 x 155 mm]
Power Terminals (for -1 and -2)	M8 x 1.25 x 10mm deep thread, 13mm hex bolt
Quick Disconnect Power Receptacle (for -3 and -4)	2-pin per MIL-PRF-18148/3 form factor (MS3509)
Communication Connector	7-pin circular
Mounting	Hold down bar (0.31 inch holes on 7.9 inch centers)

Table 1.2

Qualifications	
Certification	FAA/TSO-C179a; EASA/ETSO-C179a
Performance Qualification	RTCA/DO-311 <i>Minimum Operational Performance Standard for Rechargeable Lithium Battery Systems</i> RTCA/DO-347 <i>Certification Test Guidance For Small and Medium Sized Rechargeable Lithium Batteries and Battery Systems (partial)</i>
Environmental Qualification	RTCA DO-160G; See Section 5.7

Table 1.3

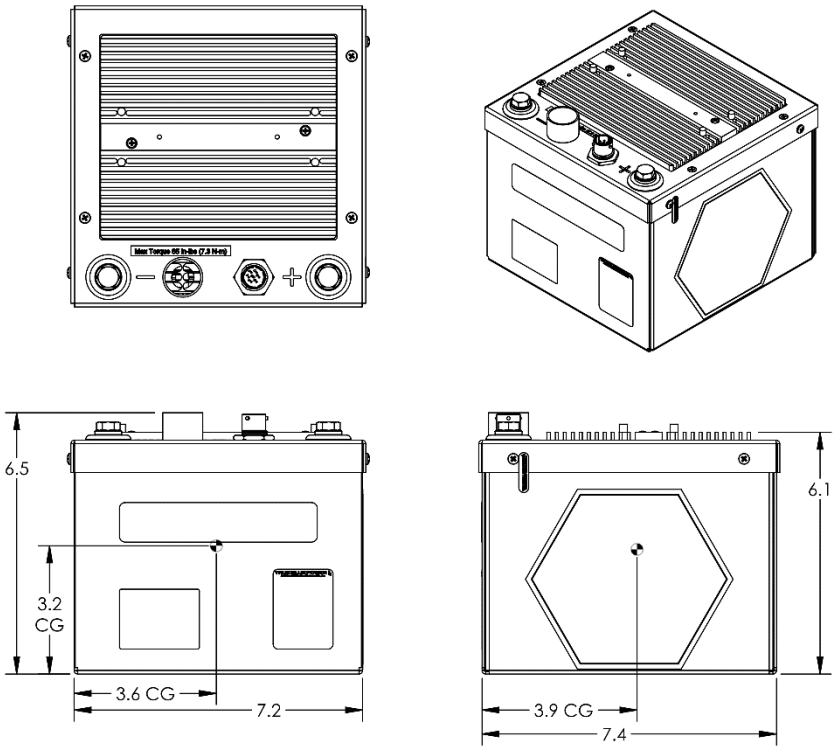

Figure 1.1
-1 and -2 Unit Outline Drawing

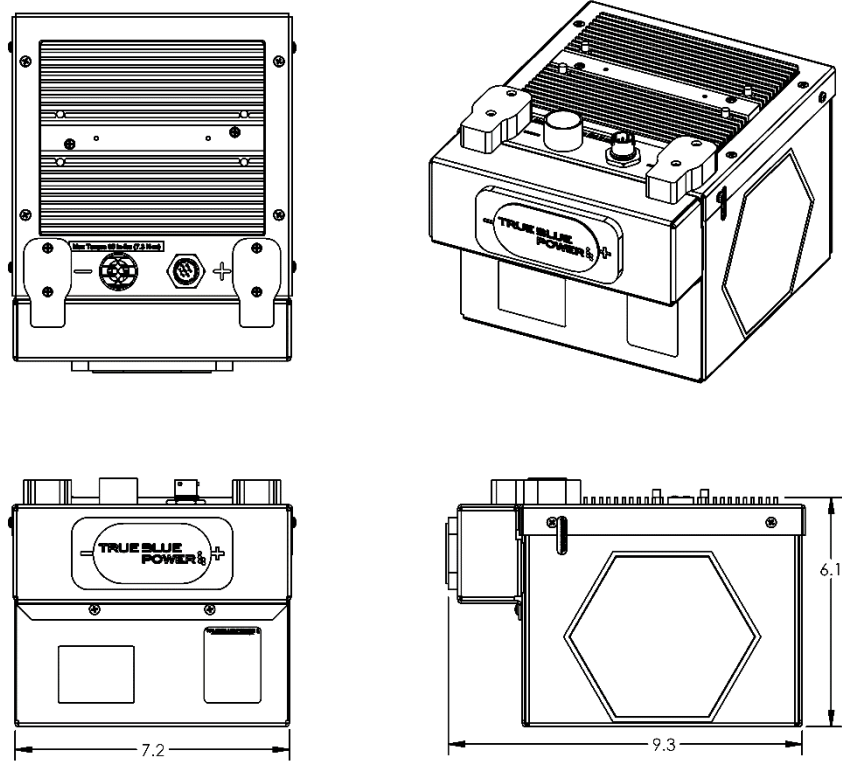

Figure 1.2
-3 and -4 Unit Outline Drawing

1.5 IMPORTANT SAFETY INFORMATION

Read this safety information BEFORE maintaining or servicing the battery.

1.5.1 Symbol Definition

This section describes the precautions necessary for safe operations. The following safety symbols have been placed throughout the guide.



Warnings identify conditions or practices that could result in personal injury.



Cautions identify conditions or practices that could result in damage to the equipment.

1.5.2 Handling Precautions



The battery's energy is high enough to sustain an ARC flash. Always wear safety glasses, fire retardant smocks, and use insulated tools when servicing the battery.

- Remove metal items such as rings, bracelets, and watches when working with battery packs. A battery could produce a short circuit current high enough to weld jewelry to metal and cause a severe burn.
- Always use appropriate Electrostatic Discharge (ESD) protection while working with the battery pack.
- All connections for battery pack testing must include appropriate short-circuit protection.
- The battery pack service area shall be properly ventilated and egress paths shall be unobstructed.
- Specialized breathing filters are not required under normal use.
- Always use insulated tools.
- Never smoke or allow a spark or flame near the battery pack.
- Use caution to reduce the risk of dropping a metal tool on the battery. Dropping a tool could spark or short circuit the battery pack.
- Turn all accessories off before removing the ground terminal.

1.5.3 Additional Precautions

The following design and operation factors are required for safe use.



- It is not acceptable to combine or use any battery cells or modules other than those approved by True Blue Power within this battery pack.
- There are no limitations in storing or using this battery in the vicinity of other battery chemistries. This battery does not emit or absorb any gas during storage, transportation or during normal operating conditions.
- Batteries must not be installed with the output terminals reversed. A reversed battery could be charged by other batteries in the circuit during discharge; or discharged by the charging system during charge.
- Battery terminals must be covered with non-conductive protective devices to avoid any possibility of shorting during handling, shipping or storage.

1.5.4 Shipping

True Blue Power lithium-ion cells and batteries are designed to comply with all applicable shipping regulations as prescribed by industry and regulatory standards. This includes compliance with the UN recommendations on the Transport of Dangerous Goods, IATA Dangerous Goods Regulations, and applicable U.S. DOT regulations for the safe transport of lithium-ion batteries and the International Maritime Dangerous Goods Code. In accordance with IATA and per UN 3480, PI 965, Section 1A and 1B, the TB17 series Advanced Lithium-ion Battery will be shipped with a state of charge (SOC) not to exceed 30% of rated capacity. This battery is classified as a Class 9 Dangerous Good. If the battery requires shipment, please contact the manufacturer for additional instructions on proper procedures.



NOTE: The unit is shipped with approximately 30% state-of-charge (SOC).
Upon receipt the battery shall be fully charged using the procedures listed in this manual (prior to storage and again prior to installation/use).

Upon receipt the battery shall be fully charged. Batteries that are stored shall be fully recharged at a minimum every 6 months, following the procedure set forth in Section 5.2.2. For more detailed storage instructions refer to Section 5.4.

SECTION 2 PRE-INSTALLATION CONSIDERATIONS

2.1 COOLING

No internal or external cooling of the unit is required. The unit is designed to operate over a wide temperature range and includes internal thermal monitoring and protection circuits. See Section 4 for more details.

2.2 EQUIPMENT LOCATION

The TB17 Advanced Lithium-ion Battery is designed for mounting flexibility, allowing for installation with no requirement for temperature or pressure control. Although not required, optimum performance and life can be achieved by mounting the TB17 in a temperature controlled section of the aircraft. In addition to altitude and temperature tolerance, the unit is designed to withstand high levels of condensing humidity. However, installation locations where the unit could be subject to standing or direct water exposure should be avoided. The unit should be mounted in the upright position (vent on top).

Failure mode, effects, and criticality analysis of the TB17 has shown that the potential for the release of toxic or flammable gases as a result of any potential condition is extremely improbable. However, for additional risk mitigation, the unit is designed with a vent which should be connected and diverted overboard in the event of such an occurrence. Details for vent installation are provided in Section 3. The unit should not be installed in compartments where lines, tanks or equipment containing fuel, oil or other flammable fluids are present. Installation near potential sources of ignition should be avoided.

Consideration should be given to how the status and reporting functions of the battery will be displayed within the aircraft. At a minimum, critical parameters determined at the time of certification should be available to the pilot and/or crew. Additionally, existing aircraft systems which are designed to work with traditional batteries may need alteration in order to accommodate the slight change in voltage output of this lithium-ion battery and the communication capabilities available.

2.3 ROUTING OF CABLES

The power terminal wires associated with the unit are heavy gauge wire and carry significant power. Be aware of routing cables near other electronics or with other wire bundles that may be susceptible to high energy flow.

Avoid sharp bends in both the power cables and the signal cabling and be cautious of routing near aircraft control cables. Also avoid proximity and contact with aircraft structures, avionics equipment, or other obstructions that could chafe wires during flight and cause undesirable effects. Cables should not run adjacent to heaters, engine exhausts, or other heat sources. The signal cable bundle wires are recommended to be no smaller than 24 gauge.

2.4 LIMITATIONS

The conditions and tests for TSO approval of this article are minimum performance standards. Those installing this article, on or in a specific type or class of aircraft, must determine that the aircraft installation conditions are within the TSO standards. TSO articles must receive additional installation approval prior to being operated on each aircraft. The article may be installed only according to 14 CFR Part 43 or the applicable airworthiness requirements.

See Section 2.2 for limitations associated with equipment installation location.

2.5 MODIFICATION

This product has a nameplate that identifies the manufacturer, part number, description, certification(s) and technical specifications of the unit. It also includes the “MOD” or modification number representing notable changes in the hardware design of the unit.

Modification (MOD) 0 is the initial release of the product and is identified on the nameplate by the lack of marking on the MOD numbers 1 through 9 (i.e. 1-9 are visible). All subsequent modifications are identified on the nameplate by the marking/blacking out of that particular MOD number (i.e. for MOD 1, the number 1 is not visible and 2-9 are visible - see Figure 2.1 for examples). MODs do not have to be sequentially inclusive and may be applied independent of each other.

For additional details regarding specific changes associated with each MOD status refer to the product published Service Bulletins at www.truebluepowerusa.com.

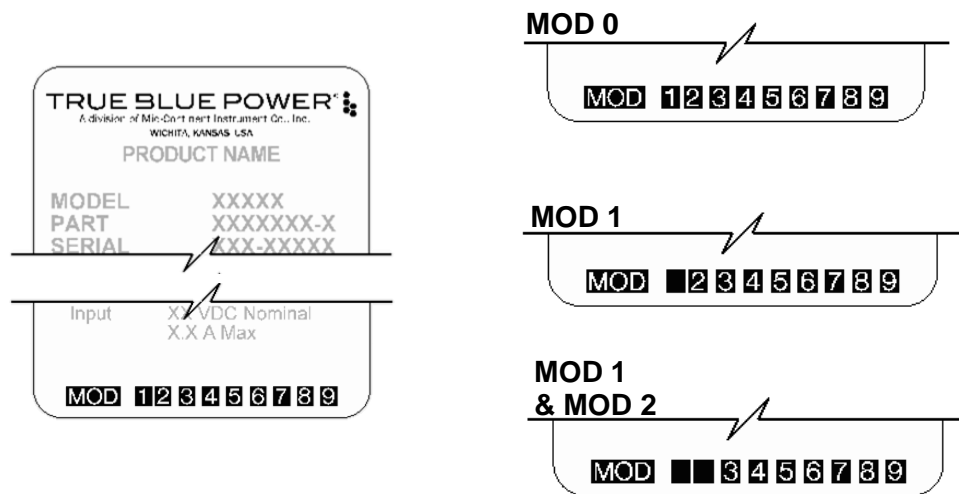

Figure 2.1

Nameplate and MOD Status Example

SECTION 3 INSTALLATION

3.1 GENERAL

This section contains mounting, electrical connections and other information required for installation. These instructions represent a typical installation and are not specific to any aircraft.

3.2 PRE-INSTALLATION INSPECTION

Unpacking: Carefully remove the TB17 battery from the shipping container. The shipping container and packing are designed specifically for the transit of lithium batteries and approved by international transportation agencies. These materials should be retained for use should the unit require future shipment.

Inspect for Damage: Inspect the shipping container and unit for any signs of damage sustained in transit. If necessary, return the unit to the factory using the original shipping container and packing materials. File any claim for damages with the carrier.

3.3 PARTS

3.3.1 Included Parts

A. TB17 Advanced Lithium-ion Battery	MCIA P/N 6430017-()
B. Hold-down bar assembly	MCIA P/N 9018087
C. Installation and operation manual	MCIA P/N 9018047

3.3.2 Available Parts

A. Connector Kit	MCIA P/N 9018048
i. Power terminal lugs	
ii. Communications connector kit	
B. Quick Disconnect Kit	MCIA P/N 9018048-1
i. Power connector kit	
ii. Communications connector kit	
C. Connector Kit, 90°	MCIA P/N 9018259
i. Power connector lugs	
ii. Communications connector kit, 90°	
D. Quick Disconnect Kit, 90°	MCIA P/N 9018259-1
i. Power connector kit	
ii. Communications connector kit, 90°	
E. Vent Kit	MCIA P/N 9018049
i. High temp vent hose (48")	
ii. Vent clamps (x2)	
F. MD41-1817 Annunciator Control Unit	MCIA P/N MD41-1817

3.3.3 Installer Supplied Parts

- A. Wires
- B. Appropriate hold-down hardware

3.4 INSTALLATION



The power terminals of the TB17 are always active and energized.
DO NOT SHORT TERMINALS AT ANY TIME!

Extreme care and caution should be applied when handling and connecting to the unit. Danger of short circuit and subsequent arc flash, electrical burns or equipment damage can occur if not handled properly.

If planning to operate two or more TB17 units in parallel, it is recommended to use -2 or -4 models.

Install the TB17 in the aircraft in accordance with the aircraft manufacturer's instructions and the following steps:

3.4.1 Harness Preparation

Prepare aircraft wiring with mating connectors in accordance with the proper Wire Size and Type (Table 3.1), Connector Locations () and Pin Identification Diagrams (Figure 3.1 and Table 3.2). Terminal bolts for negative and positive terminals torque should not exceed 65 in-lbs. (7.3 Nm).

Use of PTFE, ETFE, TFE, Teflon or Tefzel insulated wire is recommended for aircraft use. Recommended wire sizes and types are identified in Table 3.1 below. *Note: Wire gauge size for power connections is dependent on the particular aircraft installation, taking into consideration cable length, load profile, etc.

Wire Size and Type			
Wire Gauge	Wire Type	Connector	Pins
000 AWG *	Stranded Copper	Power	+/-
18-24 AWG	Stranded Copper	Comm (7-pin)	A-G

Table 3.1
Wire Size and Type

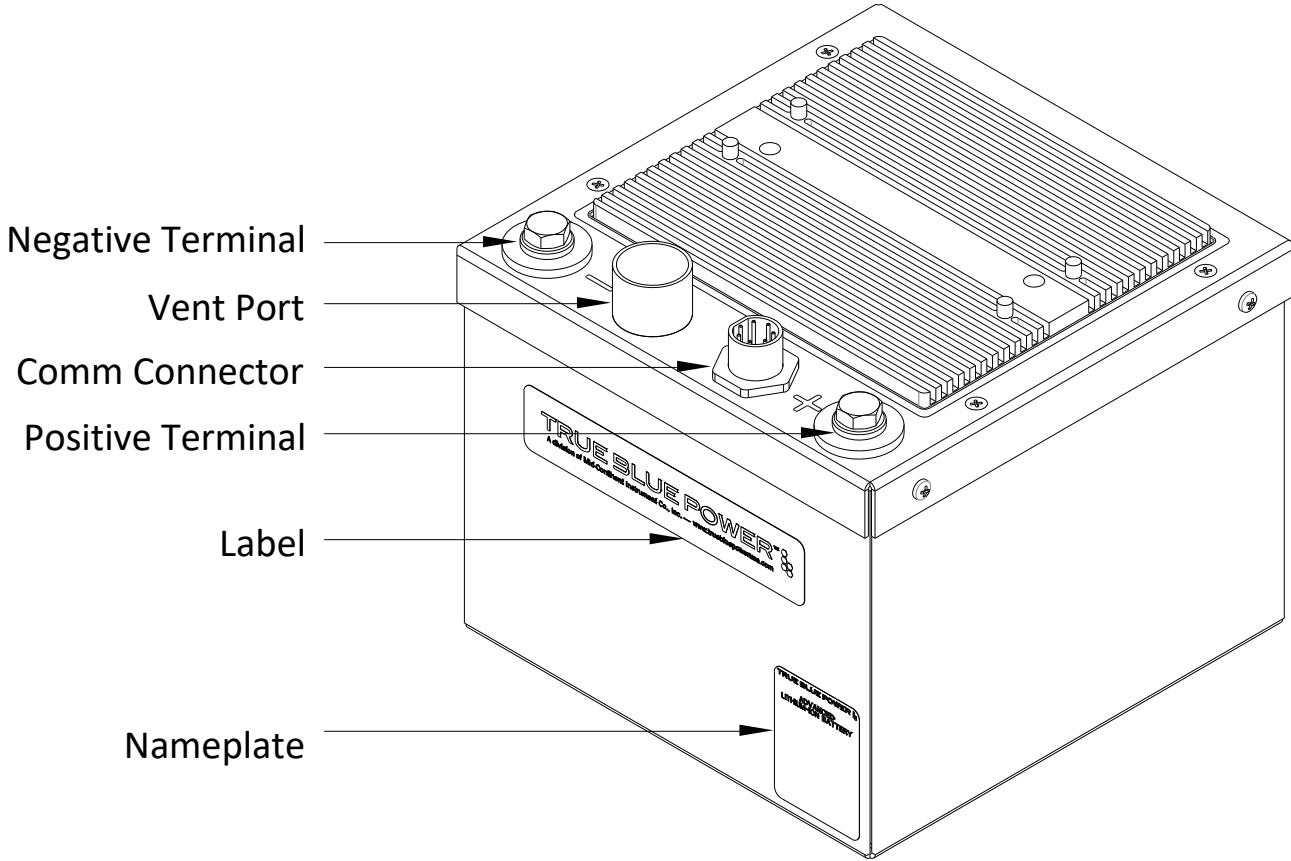

Figure 3.1
Connector Locations

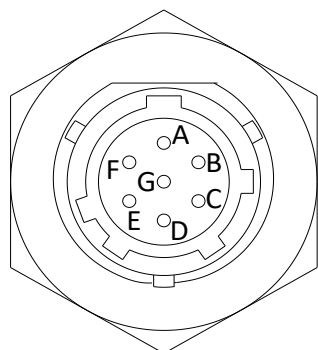

Figure 3.2
Communications Connector

Communication Connector (7-pin)		
	6430017-1/-3	6430017-2/-4
Pin	Pin Function	Pin Function
A	Fault	Fault
B	Heater	Heater
C	Charging	Charging
D	Pin 1 of RTD 1	Pin 1 of RTD 1
E	Pin 2 of RTD 1	Pin 2 of RTD 1
F	Pin 1 of RTD 2	Heater Enable
G	Pin 2 of RTD 2	Reserved

Table 3.2
Communications Connector Pinout

3.4.2 Quick Disconnect Adapter

If using the -2 or -4 units, prepare aircraft wiring with mating connectors in accordance with the proper Wire Size and Type (Table 3.1), Connector Locations (Figure 3.3) and Quick Disconnect Power Receptacle (Figure 3.4).

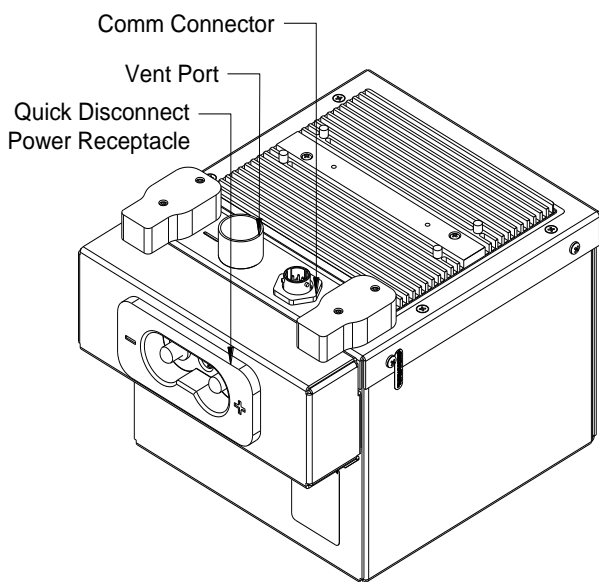
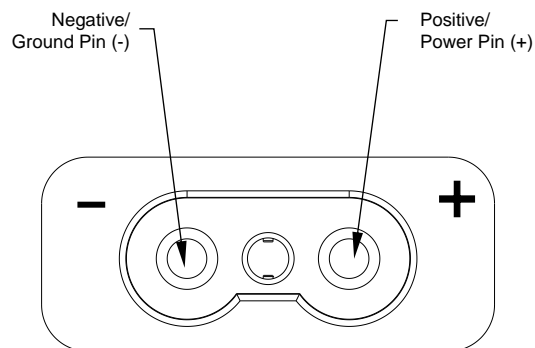

Figure 3.3
Connector Locations



Power Receptacle (2-pin)	
Pin	Pin Function
+	28VDC power in
-	aircraft ground

Figure 3.4
**Quick Disconnect
Power Receptacle**

3.4.3 Securing the Unit

The TB17 is designed to be secured in the aircraft using hold-down tie rods. The hold-down bar, TBP P/N 9017867 can be attached to the TB17 using tie down rods. The hold-down bar contains two holes, 0.310 inches (7.9 mm) in diameter, located 7.9 inches (200.7 mm) apart. Tie-down rods are inserted through the holes and tightened to approximately 20 in-lbs (2.5 Nm).

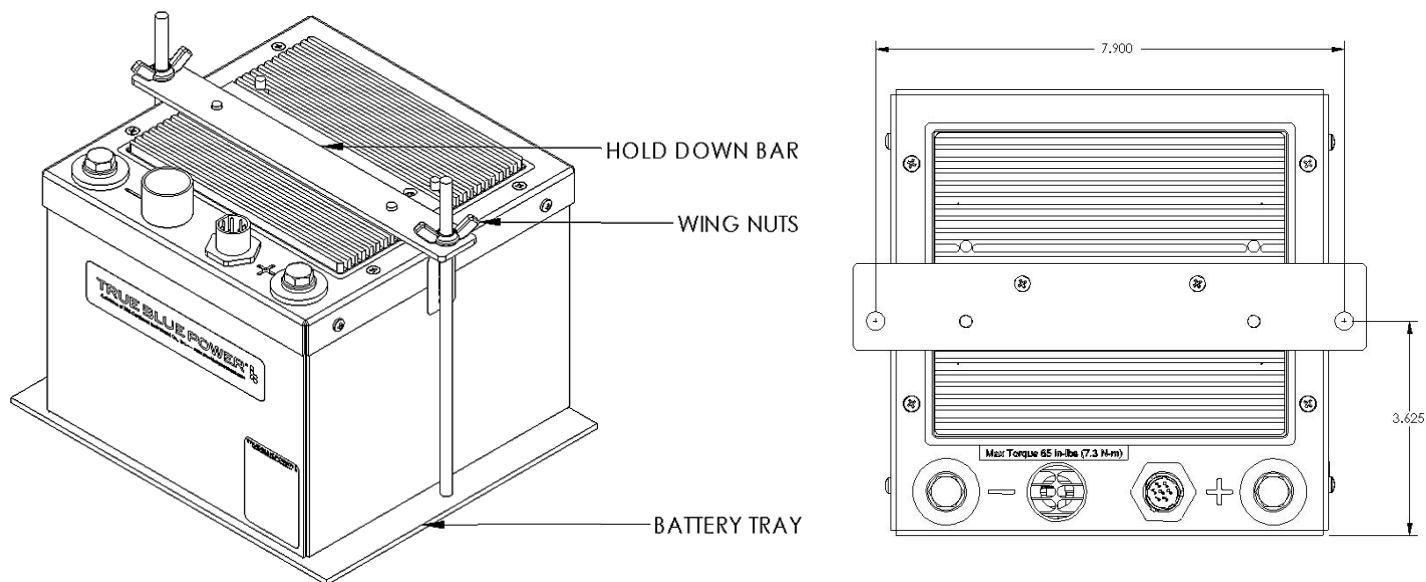

Figure 3.5
Hold-Down Bar Attachment Method

3.4.4 Vent Installation

It is recommended that the TB17 be operated with the vent tube in place when installed in the aircraft. The vent is located on the top of the unit, has a diameter of 1.0 inch (25.4 mm) and is 0.75 inches (19 mm) tall. Use the vent tube and attachment hardware as supplied in the Vent Kit, P/N 9018049. Contact True Blue Power for potential alternatives. The vent tube should be properly and securely attached to an aircraft exit point which would allow any gaseous emissions to be vented overboard. The TB17 produces no emissions during normal operation. Emissions will only be present in the event of a battery failure. Be sure to locate the vent where emitted gases would not be directed toward any of the aircraft's air intake ports.

SECTION 4 OPERATION

4.1 DESCRIPTION

The True Blue Power TB17 Advanced Lithium-ion Battery is designed to supply power for starting an aircraft engine and providing emergency backup power to aircraft systems in the event of primary power generation loss. It utilizes rechargeable Nanophosphate lithium-ion cells to deliver approximately 26.4 volts DC and 17 Ampere-hours (Ah) of capacity. It utilizes positive and negative power terminals and supplies battery status and communication through a 7-pin circular connector.

4.2 OPERATIONAL MODES

The TB17 operates in two modes. Sleep Mode reduces power consumption to conserve battery capacity. When the TB17 is in sleep mode, the internal battery heaters are inactive, communication signals are inactive, and the battery is not charging or discharging. The TB17 will transition to Active Mode when it senses a charging voltage of $100\text{mV} \pm 30\text{mV}$ greater than the battery voltage or senses an external load greater than 25mA. The unit will recycle hourly and test for these conditions in order to remain active or transition to Sleep Mode. Additionally, grounding the heater enable switch (-2 and -4 units only) will also transition the battery into Active Mode.

4.2.1 Providing Aircraft Power

When the aircraft's power generation systems are offline or fail, the unit will provide immediate power to the equipment/loads on the associated power bus. As the unit's capacity is used, the voltage will begin to drop until the unit is fully depleted. A fully charged unit will initially provide approximately 28 volts. Depending on the load, the TB17 battery will provide an average of approximately 25.5 volts for the duration of discharge. In order to avoid depleting the unit's power and ensure availability for the next flight, be sure to turn off all aircraft systems, lights and accessories after a flight. If the unit is depleted, see Section 5.2 Maintenance for charging instructions.

Discharge will be disabled once voltage drops below 20VDC. The battery will accept charge current if the battery voltage is above 12.5VDC. If battery voltage drops below 12.5VDC, it must be returned to manufacturer for repair.

4.2.2 Heating

The TB17 has the ability to be operational at temperatures down to -40°C (-40°F) utilizing the internal, self-powered heater. The TB17 is designed to support an engine start with no special considerations down to approximately -5°C (23°F), depending upon the engine start profile. Below this temperature, the performance of the unit begins to decrease in current and energy delivery as the electrolyte in the cells begins to thicken and the internal impedance increases to retard ion flow. In order to address this, each battery module contains an individual heater which is powered by the cells themselves, even at very low temperatures. Refer to Table 4.1 for specific conditions governing heater operation.

Heater Operation Condition	-1/-3 Units	-2/-4 Units
Battery is in <i>Sleep Mode</i>	Heater is disabled	Heater is disabled
Battery is in <i>Active Mode</i>	Heater is enabled	See below
Heater enable pin is grounded (-2/-4 Units only)	N/A	Heater is enabled
Heater enable pin is open (-2/-4 Units only). Note: Battery may be in <i>Sleep Mode</i> or <i>Active Mode</i>	N/A	Heater is disabled

Table 4.1
Heater Operation Condition

When the heater is enabled, it is active/on when the temperature of the battery is below +10°C. The heater will automatically turn off when it reaches +15°C. The unit will continue to monitor its temperature and turn the heater on again as needed any time the temperature drops below +10°C and the heater is enabled. This will continue during flight as needed. Pre-heat time will vary depending on temperature but can be fully warmed in 12 minutes or less after turning the heaters on. Refer to Figure 4.1 for heating time (to +15°C) based on ambient temperature.

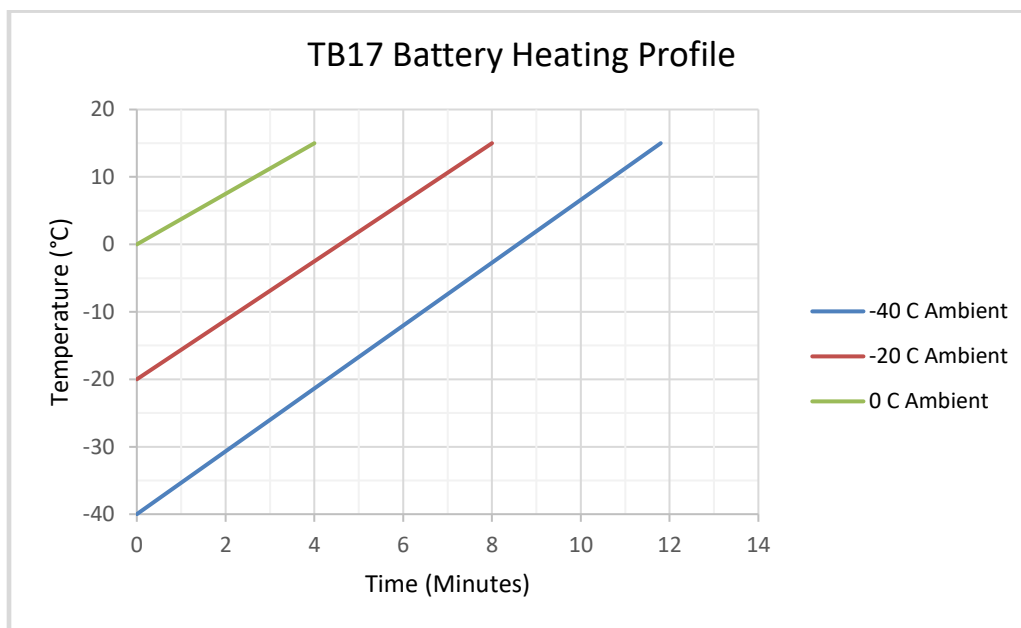

Figure 4.1
Battery Heating Profile

Normal Operating

A fully charged unit can provide up to 500 amps continuously until the battery is depleted. If the discharge current is greater than 500 amps, the battery will then limit discharge to 15 seconds.

4.2.3 Engine Start

The TB17 battery can provide current beyond 500A and up to 840A for up to 15 seconds such as when starting the aircraft engine. The low internal impedance of the Nanophosphate lithium-ion chemistry allows extremely high current delivery while maintaining higher voltage than traditional battery types. This equates to a higher total power delivery, producing quicker starts, more start attempts if needed and a higher remaining battery capacity following engine start.

4.2.4 Maintaining Charge

After engine start, the unit recharges and maintains charge by accepting power from the aircraft power generation system. During charging, the battery can draw up to 37.5A before the charge limiting activates and then restricts the input to a maximum of 34A. Even at the charge limit rate of 34A, a fully depleted unit will completely recharge in about 30 minutes. In typical applications, the unit is likely to be fully re-charged from the aircraft power generation system within several minutes following an engine start.

4.3 ACTIVE MONITORING

When in Active Mode, the TB17 presents multiple status indications to the aircraft for display and monitoring on appropriate systems. These are supplied as discrete analog signals. The various outputs and their definition are supplied below:

- **FAIL (Pin A):** A steady signal on pin A indicates a non-recoverable error.
- **FAULT (Pin A):** An alternating signal (on for 0.3 seconds; off for 0.3 seconds) indicates a recoverable error.
- **Heater (Pin B):** A steady signal on pin B indicates that the heater is active.
- **Charge (Pin C):** A steady signal on pin C indicates the battery is charging and that it is less than 95% SOC (state of charge).
- **Test (Pins A,B,C):** A steady signal on pins A, B, and C will activate for three (3) seconds when the unit initially enters Active Mode.

SECTION 5 CONFORMANCE

5.1 DISPATCH VERIFICATION AND IN-FLIGHT MONITORING

The TB17 typically serves two primary purposes on an aircraft: engine start and emergency backup power.

- Dispatch for Engine Start: In order to attempt an engine start, the user should verify that the FAULT signal is not active. It is also recommended that the HEATER signal not be active for an engine start.
- Dispatch for Emergency Backup Power: If the aircraft has a minimum backup power requirement for loss of aircraft electrical generation in emergency operation, the user may need to verify battery capacity prior to flight (see Section 5.2.3). Once battery capacity is verified as sufficient within the maintenance interval, subsequent dispatches for emergency backup power can be confirmed by verifying that the CHARGE indicator is not active.

During flight, the TB17 is capable of providing a number of status indications and battery health monitoring information to the cockpit or crew through its communication outputs (see section 4.3).

- In-Flight Monitoring: Typically, all annunciations from the unit should be inactive during flight. However, CHARGE and HEATER signals may be observed depending on the state of the unit and do not represent a hazard or loss of function. An indication of the FAULT signal or independent monitoring of the RTD sensors could require action. Consult your aircraft flight manual for details.

5.2 ROUTINE MAINTENANCE

The TB17 requires scheduled maintenance based on calendar life of the battery. Maintenance as described in this section shall be conducted every 24 months from date of original aircraft delivery or subsequent new battery installation. The battery shall be recharged every 6 months when not use.



The terminals of the TB17 are always active and energized. EXTREME care and caution should be applied when handling the unit. Danger of short circuit, electrical burns or equipment damage can occur if not handled properly. Be EXTREMELY cautious to avoid shorting terminals, dropping metal objects, hardware or tools on top of or down into the battery. REMOVE ALL JEWELRY before working with the TB17.

5.2.1 Visual Inspection

- A. Verify that proper communication is being presented to the cockpit to validate the TB17 is transmitting data appropriately. To perform this, be sure that aircraft power is off (and has been off for more than 1.0 hour – this is to assure that the battery is in sleep mode). Turn the aircraft power on (this places a load on the TB17 and places it into active mode) and verify that the three communication signals are present for 3 seconds.
- B. Remove the unit from the aircraft. Visually inspect the exterior of the battery casing for signs of damage or wear. Verify that the lid is secure and not loose. Verify that no damage has occurred which would prevent the battery from maintaining its air-tight seal. If any wear is apparent which has not compromised the case, inspect the battery area of the aircraft for any signs of improper installation.
- C. Visually inspect the power terminals and Communication connector. Verify that no connectors are loose and there are no signs of damage, wear or corrosion.
- D. If any of the above conditions are present, the unit must be evaluated and tested for repair or replacement by an authorized repair facility.

5.2.2 Charging

In order to charge the unit on the ground for capacity checks, recharges or extending storage, follow the steps listed below:

- A. Set the power supply to a constant voltage of 28.8VDC.
(If using a Christie RF80-K, see Alternate Method at the end of this section)
- B. Limit the maximum current of the power supply to 17A.
- C. Charge the battery until the charge current tapers to less than 0.7A.

Alternate Method:

- A. Using a Christie RF80-K, set the Mode Switch to “CHARGE” and the Charge Method Switch to 12 (CONSTANT POTENTIAL / CELLS LEAD ACID). Adjust charge current to 17A.
- B. With this method, the voltage will start at approximately 26VDC and a current of 17A. It will rise to approximately 28.8VDC as the current drops.
- C. Charge the battery until the charge current tapers to less than 0.7A.

5.2.3 Capacity Check

- A. Ensure that the unit is charged per Section 5.2.2 Charging.
- B. Apply a constant current load of 17A to discharge the battery pack. (Capacity check should be conducted at 23°C ±3°C (64-82°F) for accurate results.)
- C. Monitor the time (in minutes and seconds) from initially applying the constant current load in Step B until the unit has discharged down to 20.0VDC on the output.
- D. Calculate the capacity in amp-hours (Ah):

$$\text{Capacity (Ah)} = (\text{amps}) \times (\text{hours}) = (17 \text{ amps}) \times (\text{Discharge time})$$

$$\text{Discharge time (in hours)} = \text{discharge minutes} / 60$$
- E. The battery must be capable of supporting the aircraft's emergency electrical load for the required amount of time. One typical measurement for minimum capacity is 80% of original capacity (i.e. 17Ah x 80% = 13.6Ah). However, this can vary by application and could require more or less capacity to meet regulatory minimums.

5.2.4 Return to Service

- A. Recharge the unit per section 5.2.2.
- B. Measure and verify that the voltage on the unit's power terminals is greater than 27.6 VDC. A unit shall never be returned to service if the voltage is less than this value.
- C. Re-install the unit in the aircraft, including securing it via proper hold-downs, mating the electrical connections, and verifying proper vent attachment.
- D. Record service action in aircraft log book.

5.3 COMPONENT MAINTENANCE

The cells, electronics, and other components that comprise the TB17 Advanced Lithium-ion Battery are not user serviceable or replaceable items. Therefore, data is not available from the manufacturer to conduct field maintenance.

5.4 STORAGE INFORMATION

In normal use, the TB17 utilizes the aircraft power to maintain the proper charge voltage and sustain the battery cells at peak capacity. Although the chemistry of the cells used in the TB17 maintain an extremely low relative self-discharge rate, all batteries will slowly self-discharge if left unused for long periods. In addition, self-discharge rates are directly related to the storage temperature. Higher storage temperatures will result in faster self-discharge rates.

Rechargeable lithium ion batteries must be stored in a dry, well-ventilated area. They must not be kept in the same area as highly flammable materials. The unit can be stored in the same area as other battery chemistries. The TB17 does not emit or absorb any gas during storage, transportation, or during normal operating conditions.



SHELF LIFE: Per domestic and international shipping requirements, lithium-ion batteries may be shipped as low as 30% state of charge (SOC). Therefore, the battery is required to be fully recharged upon receipt. Batteries that are stored shall be fully recharged at a minimum every 6 months, following the procedure set forth in Section 5.2.2. If the storage time is unknown, a battery should be recharged prior to reaching 20V.

STORAGE TEMPERATURE: Exposure to temperatures above 30°C (86°F) for sustained periods of time is possible, but may increase the self-discharge rate or result in some permanent loss of capacity. Storage temperatures above 50°C (122°F) are to be avoided.

5.5 END OF LIFE

Estimated life for the TB17 Advanced Lithium-ion Battery is expected to exceed six (6) years. The unit has reliably demonstrated over 13,000+ engine starts and subsequent charge cycles. The cells themselves are designed for a useful life of up to ten (10) calendar years.

The following conditions will help maintain or extend the life and performance of your product:

- Avoid significant exposure to high temperatures (above 30°C/86°F) during operation or storage
- Avoid long periods (greater than 7 days) at a state of full discharge
- Avoid long periods of storage (greater than 6 months) without recharge

End of life is represented by the inability of the unit to meet the minimum capacity requirement of the aircraft as tested during capacity verification per Section 5.2.3. In the event that the unit exhibits failure, insufficient capacity or expired life, contact True Blue Power for repair, exchange or replacement. Visit www.truebluepowerusa.com for more information.

5.6 DISPOSAL



NOTE: All lithium ion batteries are classified by the United States government as non-hazardous waste and are safe for disposal as normal municipal waste. However, these batteries do contain recyclable materials and recycling options available in your local area should be considered when disposing of this product. Dispose of in accordance with local and federal laws and regulations. Do not incinerate.

5.7 ENVIRONMENTAL QUALIFICATION STATEMENT

MODEL NUMBER: TB17 Series **PART NUMBER:** 6430017-()
DESCRIPTION: Advanced Lithium-ion Aircraft Battery **CERTIFICATION:** FAA TSO-C179a
MANUFACTURER: True Blue Power, a division of Mid-Continent Instrument Co., Inc.
ADDRESS: 9400 E. 34th St. North, Wichita, KS 67226, USA.
SPECIFICATION: Test Specification (TS) 116 Test Data Sheet (TDS) 416
STANDARD: RTCA DO-160, Rev G, dated 12/08/10

CONDITIONS	SECTION	DESCRIPTION OF TEST
Temperature and Altitude	4	Category F1
Temperature Variation	5	Category S2
Humidity	6	Category B
Operational Shock and Crash Safety	7	Category B
Vibration	8	Fixed Wing: Category S; Curve C Rotorcraft: Category U; Curve G
Explosion	9	Category H
Waterproofness	10	Category W
Fluids	11	Category F
Sand and Dust	12	Category S
Fungus	13	Category F
Salt Fog	14	Category S
Magnetic Effect	15	Category Z
Power Input	16	Category B(RI)
Voltage Spike	17	Category A
Audio Freq Conducted Susceptibility	18	Category B
Induced Signal Susceptibility	19	Category ZC
Radio Frequency Susceptibility	20	Category RR
Emission of Radio Freq Energy	21	Category L
Lightning Induced Transient Susceptibility	22	Category A3J4L3
Lightning Direct Effects	23	Category X
Icing	24	Category X
ESD	25	Category A
Fire, Flammability	26	Category C

REMARKS:
 Section 4: Category F1 with excursions as declared by the manufacturer:
 • 4.5.4: Operating High Temp +70°C
 • 4.6.2: Decompression +8,000 feet

 Section 11: Fluid classes include fuels, hydraulic fluids, lubricating oils, solvents/cleaning fluids, de-icing and sillage.